



## BeachBUB

Patent<sup>x</sup> Case Study 005  
William Fisher  
October 2021

The primary purpose of a beach umbrella is to protect the user from excessive sun. Photographs of some typical examples appear below.



Almost all commercially available beach umbrellas work adequately when the weather is calm. Many, however, are unable to withstand significant amounts of wind. Prior to 2009, a few companies offered for sale umbrellas specifically designed to be usable in windy conditions. Three are depicted below.



## Umbrella Support Pole Details

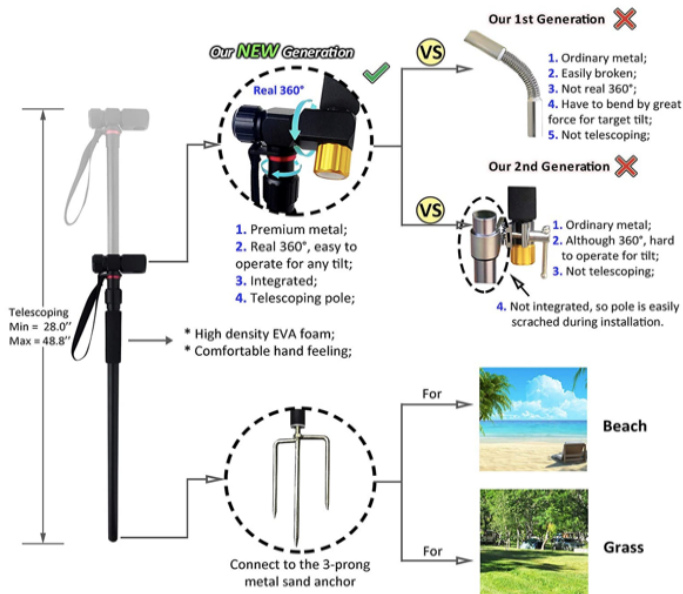

Sunphio Large Windproof Beach Umbrella, Sturdy and UV Protection, Portable Sun Shade Best for Camping, Picnic, Sand, Patio and More, 2 Metal Sand Anchor, 1...



In 2009, Bill Schermerhorn developed what he claimed was a superior design for a wind-resistant beach umbrella. The genesis of his invention is described in the following article.

John Osborne  
 “Inventor takes on sun, wind with beachBUB  
 umbrella base conceived in Naples”  
 Naples Daily News  
 May 22, 2014

Some inventions are made in the shade. That was the case for the beachBUB, a beach umbrella base which traces its origins to Naples, [Florida].

Five years ago on Mother's Day, Bill Schermerhorn and his wife, Christine, were sitting on Vanderbilt Beach outside the Ritz-Carlton, watching a woman struggle with her beach umbrella, when inspiration struck.

"It was a sunny, windy day," recalled Schermerhorn, a business-products company owner who splits his time between Naples and Colfax, N.C. "The lady upwind from us was trying to secure her umbrella with one of those traditional screw contraptions, and not having much success."

After five minutes of watching the woman wrestle with her umbrella, Schermerhorn said, the woman finally completed her task and sat down in her beach chair before opening a book.

"That was when a gust of wind came along and almost tore her umbrella from the sand, causing her to grab onto the pole to keep it in place,"

he said. When the same thing happened a few moments later, Schermerhorn decided he needed to step in and get involved.

"Since we were sitting downwind of her, I knew we wouldn't be able to relax until the umbrella was stabilized, so I went over and asked her if I could help," he said. Once Schermerhorn had dug a deep hole in the sand to keep the pesky umbrella from going anywhere, he returned to his patch of beach and did a little reconnaissance work.

"It was a blustery day, and a lot of umbrellas were up, but they were closed," he said. "One of the umbrellas even flew down the beach and hit a family. I thought to myself: there's got to be a better way."

Following that train of thought to patio umbrellas and how they work, Schermerhorn envisioned what would eventually become the beachBUB, which stands for "beach umbrella base."

"Patio umbrella stands have a big base -- 60 to 80 pounds -- and they do a great job," he said. "I began thinking about how I could get a stand like that on the beach that's easy to transport."

Upon returning home that day, Schermerhorn visited a local home improvement store and a fabric store and started tinkering with a prototype.

"I made it out of a fabric similar to the blue tarp people use for gardening," he said. "The next day I took it to the beach ... and it worked great."

"The beachBUB tarp has three wings and a hole in the middle," he explained. "With a one-time setup, you take your pole and the collar we include and anchor it by screwing in three hook-bolts, like a Christmas tree stand."

From there, Schermerhorn said, all you need to do is poke your umbrella pole three or four inches into the sand, attach the wings and add sand.

"The beachBUB weighs less than a pound and is very simple to transport," he said. "We have testimonials from 5-year-olds to 85-year-olds saying how easy it is to set up, and we've tested it with an 11-foot Ocean Master umbrella in 42 mph winds and it stays rock solid."

Schermerhorn has sold more than 500 units while test-marketing the beachBUB at a farmer's market on the corner of Vanderbilt Beach and Airport-Pulling roads, which encouraged him to continue pursuing the idea.

"The response was overwhelming," he said. "We did our first production run last year, and we're getting ready to do our second production run now."

An illustration of the invention appears below.



An explanation of how it works is provided in this video: <https://www.youtube.com/watch?v=lsPyYI7cPCw>.

Many patents filed prior to 2009 address various aspects of the technology of beach umbrellas, but you may assume that only one is relevant to Schermerhorn's innovation. It is set forth below.



[54] **BEACH UMBRELLA SUPPORT**  
 [76] Inventor: **Richard W. Archer**, 4/66 Beresford Rd., Rose Bay, New South Wales, 2029, Australia

3,216,681 11/1965 Tagliavia ..... 248/346 X  
 3,285,203 11/1966 Meyer ..... 108/50  
 4,148,455 4/1979 Oliver ..... 248/158 X

[21] Appl. No.: **10,407**  
 [22] Filed: **Feb. 8, 1979**  
 [51] Int. Cl.<sup>3</sup> ..... **A47B 41/04; A47B 35/00**  
 [52] U.S. Cl. .... **108/28; 108/50; 248/158; 248/DIG. 10**  
 [58] Field of Search ..... **108/28, 26, 50; 248/158, 346, 545, 523, DIG. 10**

**FOREIGN PATENT DOCUMENTS**

994741 2/1973 Canada ..... 248/158

*Primary Examiner*—Roy D. Frazier  
*Assistant Examiner*—Peter A. Aschenbrenner  
*Attorney, Agent, or Firm*—Emory L. Groff, Jr.

[57] **ABSTRACT**

A beach umbrella support is formed by a collapsible container which can be filled with solid or liquid material to give it stability. Means are provided to retain the beach umbrella shaft in the container and the container itself can be provided with handles and pockets to double as a beach bag. Corner rods can be provided for additional stability and a table top can also be provided.

[56] **References Cited**

**U.S. PATENT DOCUMENTS**

1,936,428 11/1933 Friesner ..... 108/50 X  
 1,986,140 1/1935 Dapp ..... 248/158  
 2,039,805 5/1936 Knight ..... 108/50  
 2,195,391 3/1940 Hunter ..... 108/50 UX  
 2,883,247 4/1959 Thompson ..... 108/50 UX

**3 Claims, 2 Drawing Figures**

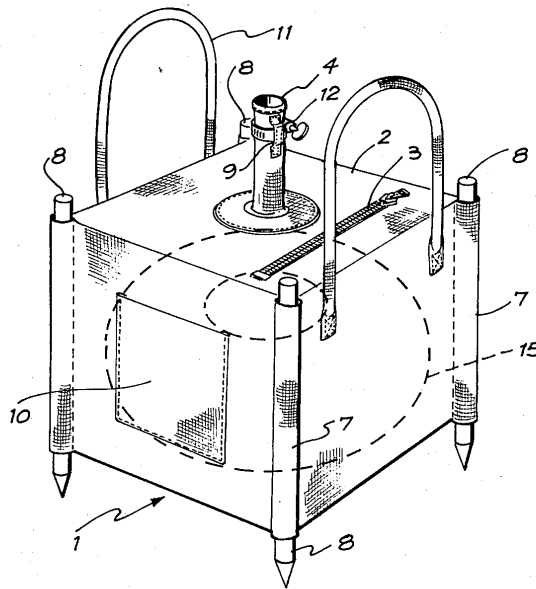

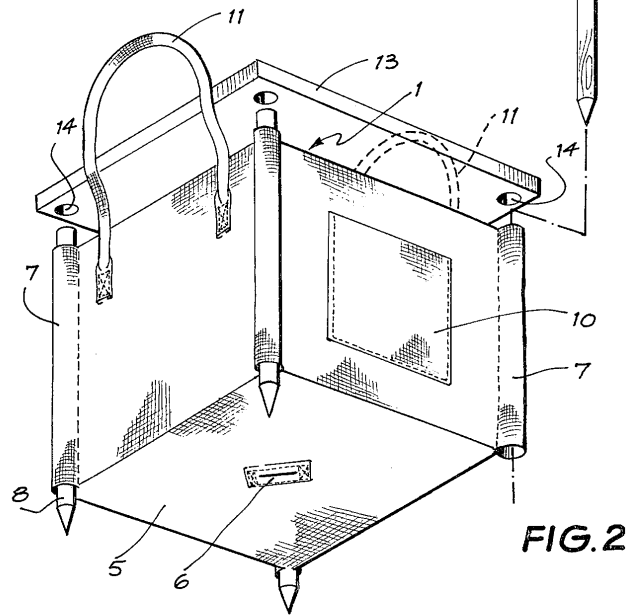
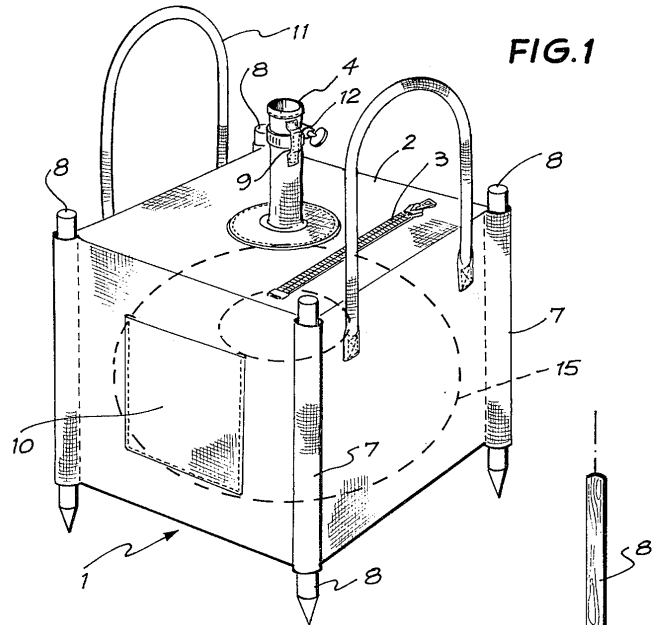

## BEACH UMBRELLA SUPPORT

The invention relates to an umbrella support and more specifically to a support for a sun shade commonly called a beach umbrella.

Such umbrellas are generally provided with a spiked shaft which is pushed into the beach sand. As the sand is rather loose, the umbrella can easily be turned over by a moderate breeze and serious accidents have been the result of such umbrellas being blown along the beach.

Various attempts have been made already to overcome these drawbacks by providing the spike with a thread to screw the umbrella shaft into the ground. Various types of plates at the spiked end have also been proposed, but none of these arrangements have proved to be successful, as in many cases the umbrella is first rotated by the wind thereby loosening its hold in the ground. It then requires only a minor wind force to topple the umbrella and drive it along the ground.

It is also known to provide a heavy stand for such umbrellas when the latter are used as sun shades on concrete surfaces. These stands consist generally of a heavy bottom plate of iron with a tube extending upwards therefrom to receive the umbrella shaft. The weight and size of such stands make them, however, unsuitable for use at the beach.

It has also been proposed to use a bag which can be filled with sand to stabilize the beach umbrella but such arrangements were also not successful.

It is an object of the present invention to provide a beach umbrella support which is easily transportable, prevents rotation of the umbrella by the wind and subsequent lifting and toppling over.

This object is achieved according to the invention by a beach umbrella support comprising a flat bottom collapsible container adapted to receive solid or liquid material, a tubular member extending centrally from the top of said container and adapted to receive the shaft of a beach umbrella, means to clamp said beach umbrella shaft to said tubular member and a central opening in the bottom of said container large enough to allow the beach umbrella shaft to pass therethrough.

One embodiment of the invention will be described hereinafter in more detail in connection with the drawings in which:

FIG. 1 is a perspective top view of a beach umbrella support according to the invention and

FIG. 2 is a bottom perspective view of the support shown in FIG. 1.

In this particular embodiment the container 1 forming the main support for the beach umbrella, has a substantially cubic shape, made from a heavy canvas or plastic material, so that it can be filled with sand. In case water is to be used as stabiliser a doughnut shaped bag 15 of waterproof material can be inserted in the container.

The top part 2 of the container has an opening closed by a zip fastener 3 which allows the container 1 to be filled or emptied. A tubular member or sleeve 4 is arranged centrally on the top part 2 of the container 1 and has an internal diameter large enough to receive an umbrella shaft with a loose fit. The tubular member or sleeve 4 is preferably made of the same material as the container. The bottom part 5 of the container has a

reinforced slot 6 wide enough to allow the beach umbrella shaft to be pushed therethrough.

In some cases it is advantageous to facilitate filling of the container 1 by providing the four vertical edges with sleeves or pockets 7 retaining four vertical rods 8, which not only serve to stabilize the collapsible container 1 while it is filled, but can also serve as supports for a table top 13, which may be placed on top of the container after it has been filled.

This table top 13, which is made of any suitable material, has a central hole fitting over the abovementioned sleeve 4 and may have four recesses 14 engaging the corner rods 8 of the container 1.

The shaft of the beach umbrella is pushed through the sleeve 4 and the opening 6 in the bottom part 5 of the container and a clamp 9 with thumb screw 12 on the sleeve 4 secures the umbrella shaft in the sleeve 4 preventing any longitudinal as well as any rotating movement of the umbrella.

The container 1 can be made big enough to safely support a beach umbrella in normal wind forces, as it occupies only a very small space when it is in the collapsed state. It has been found that a container of one cubic foot will be sufficient for normal requirements.

If the container is made water tight or provided with a water tight insert as mentioned above the umbrella support can be used also in all places where sand is not readily available. It must be understood that other material, for example rocks, can also be used as filling.

The container 1 can be provided with additional pockets 10 and handles 11 so that it can be used as a beach bag before the beach umbrella is erected.

The foregoing detailed description deals only with one embodiment of the invention. It must be understood however, that modifications can be made in the shape of the container and the fixture of the umbrella shaft therein within the scope of the present invention.

I claim:

1. A support for the shaft of a beach umbrella comprising a flat bottom collapsible container adapted to receive solid or liquid material, said container having a top part with a filler opening therein, a tubular member extending centrally from the top part of said container and adapted to receive the shaft of said beach umbrella, means to clamp said beach umbrella shaft to said tubular member, a central opening in the bottom of said container large enough to allow said beach umbrella shaft to pass therethrough and a doughnut shaped water-tight insert in said container.

2. A support for the shaft of a beach umbrella comprising a flat bottom collapsible container adapted to receive solid or liquid material, said container having a top part with a filler opening therein, a tubular member extending centrally from the top part of said container and adapted to receive the shaft of said beach umbrella, means to clamp said beach umbrella shaft to said tubular member, a central opening in the bottom of said container large enough to allow said beach umbrella shaft to pass therethrough, a sleeve at each of the four vertical corners of the container and a rod in each of said sleeves extending beyond the top and the bottom of said container.

3. A support for the shaft of a beach umbrella according to claim 2 and including a table top mounted on said rod, said table top having a central opening fitting over the beach umbrella shaft, and said rods engaging corresponding recesses in said table top.

\* \* \* \* \*

Imagine that it is now January 1, 2009. You are a member of a team that has been asked to assist in drafting an application for a U.S. patent that, if granted, would maximize Schermerhorn's legal leverage. With his aid, your team has put together the tentative specification set forth below:

## BACKGROUND OF THE INVENTION

The need to anchor umbrellas and other such devices against unwanted movement has long been understood as is evidenced by previously presented devices for same. Some devices require carrying some form of weight to add low level mass to the umbrella in order to resist movement caused by wind for example. Other devices require anchors much like those of a tent, such as stakes, screws and other such devices, or even anchors with guy wires. Other like devices require filling and emptying of a vessel. Such vessels are inconvenient, especially in emptying, and also limit what may be used to fill the vessel. Some anchoring devices are added to an existing umbrella assembly in some way, yet device additions inherently limit superior design and function. The present apparatus provides a complete anchorable umbrella and allows easy fill and emptying without a defined vessel, and needs no transportable weight, and thereby provides a truly lightweight and portable apparatus.

## FIELD OF THE INVENTION

The anchorable umbrella apparatus relates to umbrellas, umbrella stands, and related stanchions with supports and more especially to a complete anchorable umbrella assembly that negates transporting weights and filling of a defined vessel.

## SUMMARY OF THE INVENTION

The general purpose of the anchorable umbrella apparatus, described subsequently in greater detail, is to provide an anchorable umbrella apparatus which has many novel features that result in an improved anchorable umbrella apparatus which is not anticipated, rendered obvious, suggested, or even implied by prior art, either alone or in combination thereof.

To attain this, the anchorable umbrella apparatus provides for use as more than just an umbrella. The apparatus may be topped with the folding umbrella. The first section may also be topped with a signpost, banner, or other useful feature or object. Of great importance is that the apparatus need not carry any additional weight, such water or sand as are often used, in order to be strongly anchored to surface. The apparatus importantly also need not be staked like tents and the like, which can be difficult if not impossible in rocky ground, for example. Also, sandy surface materials need extremely long stakes in order to attempt to accomplish what the apparatus design does without stakes.

The apparatus offers further advantages by being easily filled and emptied of surrounding materials, such as rock, sand, and dirt, for example. The apparatus, therefore, provides very important lightweight portability and installation advantages as opposed to other such devices that must either have to have a vessel filled with water or sand or the like or be staked, for example. Carrying or supporting, filling, and especially emptying any defined vessel is not only inconvenient, but cumbersome and much more difficult than is filling the tarp of the present apparatus.



The present apparatus requires no tools, not even a screwdriver, no ties or tying and is a complete apparatus, except for the chosen tarp fill. Further, the present apparatus supports whatever device is affixed to the first section unidirectionally, such that no wind direction need be considered. The cam lock used to selectively locate the first section within the second section of the pole provides positive and rapid performance. The guide within the lower portion of the second section importantly prevents a user from having to guess how deeply to embed the pole and where to properly locate the collar for best selected fill performance, as well as aiding in providing a range of best collar location performance. Another advantage of the guide is that the selectively tightened butterfly bolts also perform as grommet anchors for the tarp.

The apparatus may or may not have delineated divisions between the inner isosceles triangle and the outer triangles. The triangular division delineations may also only be used for explanation purposes.

Additionally, the delineated divisions may assist users in installation by helping to define fill capacities of various weighting materials. The apparatus, while in illustration features a hexagonal shape, may be produced as a triangle. The apparatus tarp may be supplied with any number of spaced apart grommets. The hexagonal illustration with three grommets is an ideal embodiment but the apparatus is in no way limited to a hexagonal shape, nor to a triangular shape. The apparatus collar with spaced apart butterfly bolts is not limited to three bolts nor is the tarp limited to three grommets.

Thus has been broadly outlined the more important features of the improved anchorable umbrella apparatus so that the detailed description thereof that follows may be better understood and in order that the present contribution to the art may be better appreciated.

An object of the anchorable umbrella apparatus is to provide an easily anchored apparatus.

Another object of the anchorable umbrella apparatus is to provide extreme portability.

A further object of the anchorable umbrella apparatus is to negate additional anchoring devices.

An added object of the anchorable umbrella apparatus is to negate the use of transported weight.

Still another object of the anchorable umbrella apparatus is to negate the use of a defined vessel.

Yet another object of the anchorable umbrella apparatus is to provide superior anchoring in windy conditions.

These together with additional objects, features and advantages of the improved anchorable umbrella apparatus will be readily apparent to those of ordinary skill in the art upon reading the following detailed description of presently preferred, but nonetheless illustrative, embodiments of the improved anchorable umbrella apparatus when taken in conjunction with the accompanying drawings.

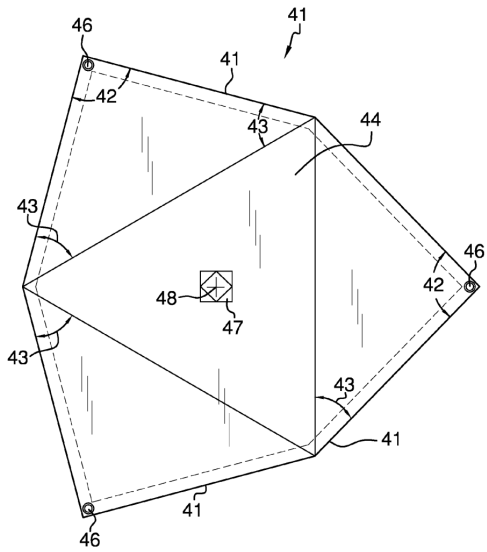

FIG. 1

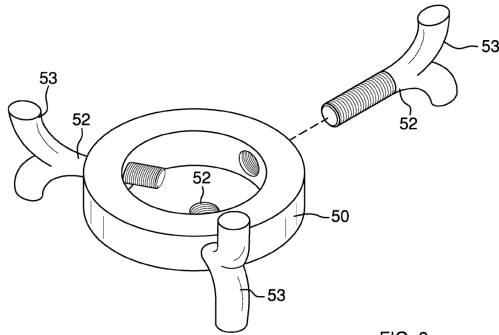

FIG. 2

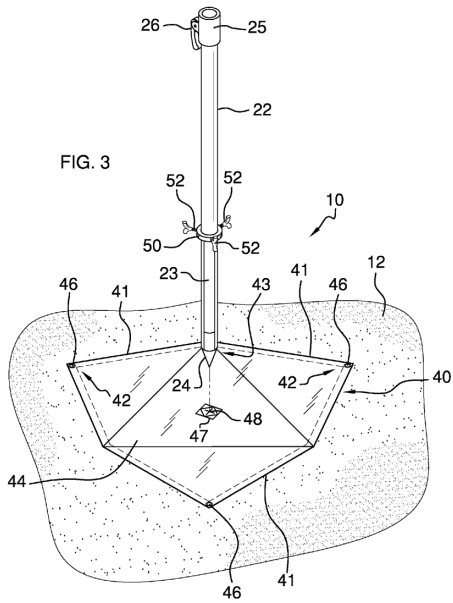

FIG. 3

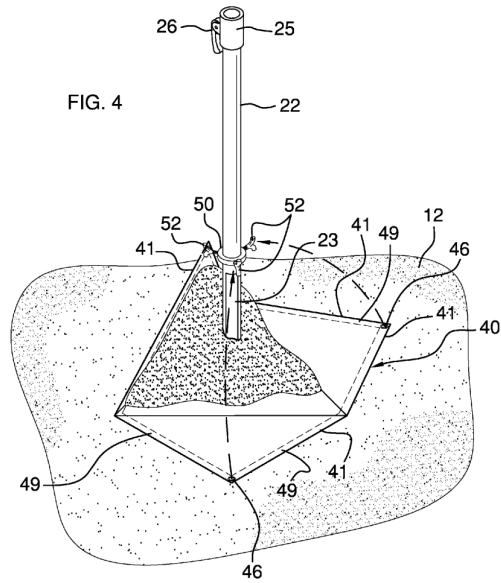
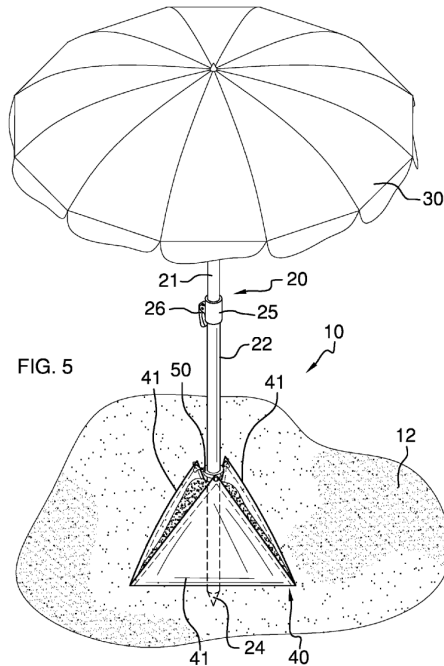

FIG. 4



## BRIEF DESCRIPTION OF THE DRAWINGS

FIG. 1 is a top plan view of the tarp.

FIG. 2 is a perspective view of the collar with butterfly bolts.

FIG. 3 is a perspective view of the tarp located on an existing surface, with section pole section in preparation of fit within the tarp opening.

FIG. 4 is a perspective view of the tarp fitted to an existing surface, with a portion of the surface within the tarp and with the pole second section fitted within the tarp opening.

FIG. 5 is a perspective of the apparatus fully in use.

## DETAILED DESCRIPTION OF THE DRAWINGS

With reference now to the drawings, and in particular FIGS. 1 through 5 thereof, the principles and concepts of the anchorable umbrella apparatus generally designated by the reference number **10** will be described.

Referring to FIG. 5, the apparatus **10** partially comprises the pole **20** having a first section **21** slideably and removably fitted within the second section **22**. The receiver **25** is disposed atop the second section **22**. The first section **21** is fitted within the receiver **25**, and the cam lock **26** disposed on the receiver **25** selectively tightens the first section **21** at a desired height within the second section **22**. The folding umbrella **30** is fitted atop the first section **21**.

Referring to FIG. 3, the pointed tip **24** is disposed downwardly on the second section **22**. The visual guide **23** is disposed downwardly on the second section **22**. The collar **50** is slideably fitted around the pole **20** second section **22**.

Referring to FIG. 2, the trio of equally spaced apart butterfly bolts **52** is radially and threadably inserted through the collar **50**. A Y end **53** is disposed outwardly on each butterfly bolt **52**.

Referring to FIG. 1, the hexagonal tarp **40** partially comprises the isosceles inner triangle **44**. The reinforcement **47** is disposed centrally within the isosceles inner triangle **44**. The opening **48** is disposed within the reinforcement **47**. An outer triangle **42** abuts each side of the isosceles inner triangle **44**.

Each outer triangle **41** further comprises an outer angle **42** of about 90 degrees and a pair of spaced apart companion angles **43** of about 45 degrees each. A grommet **46** is disposed within the outer angle **42** of each outer triangle **41**.

Referring to FIG. 4 and FIG. 5, each grommet **46** is selectively engaged with one of each of the Y ends **53** of one of each of the butterfly bolts **52**. The overlapping border **49** is disposed totally around the tarp **40** and ensures strength and insures against failure. In use, the tarp **40** is place upon an existing surface **12**, such as beach sand for example. The pole **20** second section **22** is inserted through the opening **48** with the pointed tip embedded into the surface **12**. The second section **22** is embedded such that the bottom of the guide **23** is at about surface **12** level. The beach sand is used to fill the inner triangle **44** and also into the outer triangles **41**. Each outer triangle **41** is lifted such that one of each grommet **46** can be hooked on one of each of the butterfly bolt **52** Y ends **53**. The apparatus **10** is thereby inserted into the surface **12** and weighted upon the surface **12** by the surface **12** itself. Removal is reversal is installation.

Directional terms such as "front", "back", "in", "out", "downward", "upper", "lower", and the like may have been used in the description. These terms are applicable to the embodiments shown and described in conjunction with the drawings. These terms are merely used for the purpose of description in connection with the drawings and do not necessarily apply to the position in which the anchorable umbrella apparatus may be used.



As you now know, the most important step in preparing a patent application is drafting the claims. In class, you will work with a small group of fellow students to create claims on behalf of Schermerhorn. To prepare for this exercise you should:

- (a) read pages 33-42 and 67-82 in the [WIPO Patent Drafting Manual](#);
- (b) write down – and bring to class – a preliminary draft of the claims;
- (c) consider whether the tentative claims you have drafted would suggest or require any revisions of the specification set forth above.